



US 20180286925A1

(19) **United States**

(12) **Patent Application Publication**

**Kim et al.**

(10) **Pub. No.: US 2018/0286925 A1**

(43) **Pub. Date: Oct. 4, 2018**

(54) **ORGANIC LIGHT EMITTING DISPLAY DEVICE**

(52) **U.S. Cl.**  
CPC ..... **H01L 27/323** (2013.01); **H01L 51/5203** (2013.01); **H01L 51/5044** (2013.01)

(71) Applicant: **Samsung Display Co., Ltd.**, Yongin-si (KR)

(72) Inventors: **Kwangmin Kim**, Yongin-si (KR); **Wonkyu Kwak**, Yongin-si (KR); **Kiwook Kim**, Yongin-si (KR); **Dongsoo Kim**, Yongin-si (KR); **Joongsoo Moon**, Yongin-si (KR); **Hyunae Park**, Yongin-si (KR); **Jieun Lee**, Yongin-si (KR); **Changkyu Jin**, Yongin-si (KR)

(57) **ABSTRACT**

An organic light emitting display device includes: a substrate including pixel areas and a pixel separating area; a plurality of pixels; a plurality of spacers in the pixel separating area and spaced apart from each other; and a touch electrode unit disposed over the plurality of pixels and spacers. The touch electrode unit includes first touch electrodes arranged in a first direction and second touch electrodes arranged in a second direction. The touch electrode unit includes a plurality of touch pattern unit blocks repeatedly arranged. Each touch pattern unit block includes portions of each of neighboring first touch electrodes and portions of each of neighboring second touch electrodes. The spacers of each touch pattern unit block corresponds to a plurality of spacer pattern unit blocks repeatedly arranged. Each spacer pattern unit includes at least one spacer and is smaller than the touch pattern unit block.

(21) Appl. No.: **15/833,265**

(22) Filed: **Dec. 6, 2017**

(30) **Foreign Application Priority Data**

Mar. 30, 2017 (KR) ..... 10-2017-0041060

**Publication Classification**

(51) **Int. Cl.**  
**H01L 27/32** (2006.01)  
**H01L 51/50** (2006.01)  
**H01L 51/52** (2006.01)

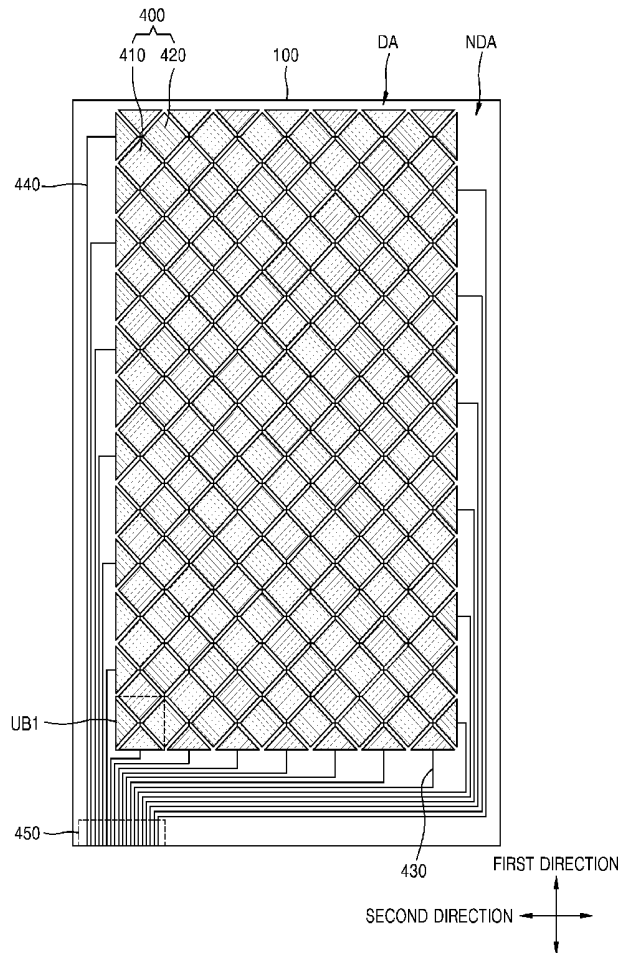

FIG. 1

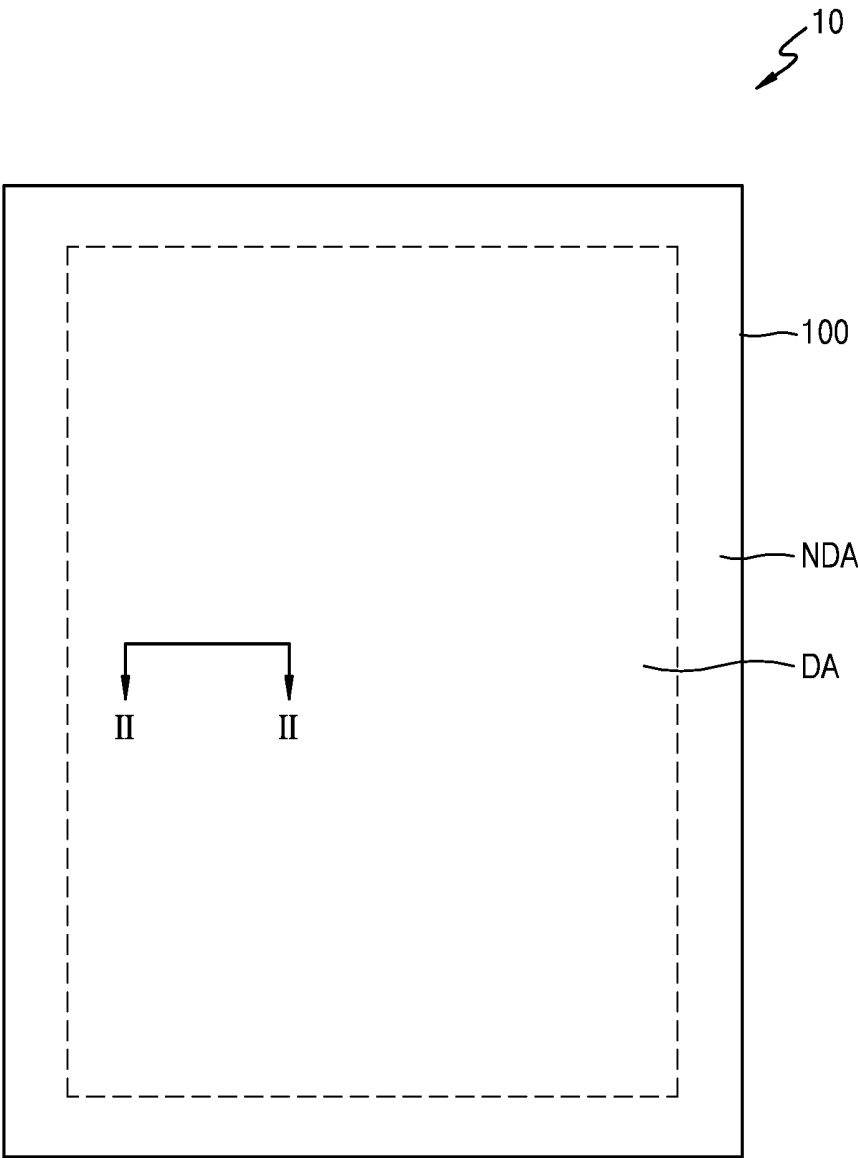

FIG. 2

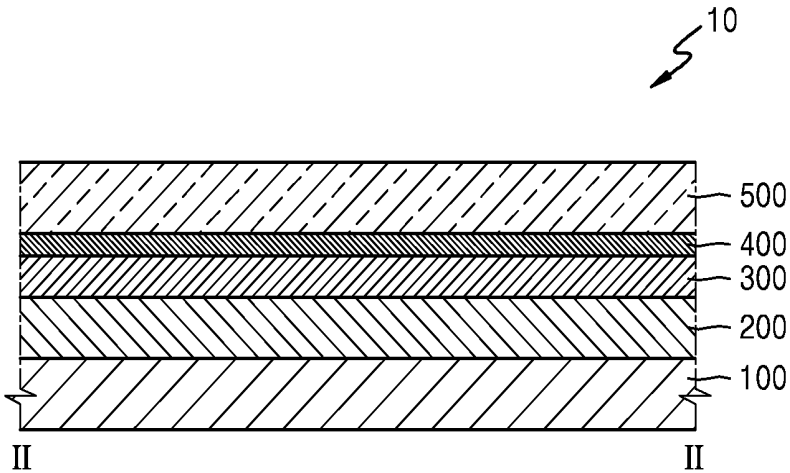



FIG. 4

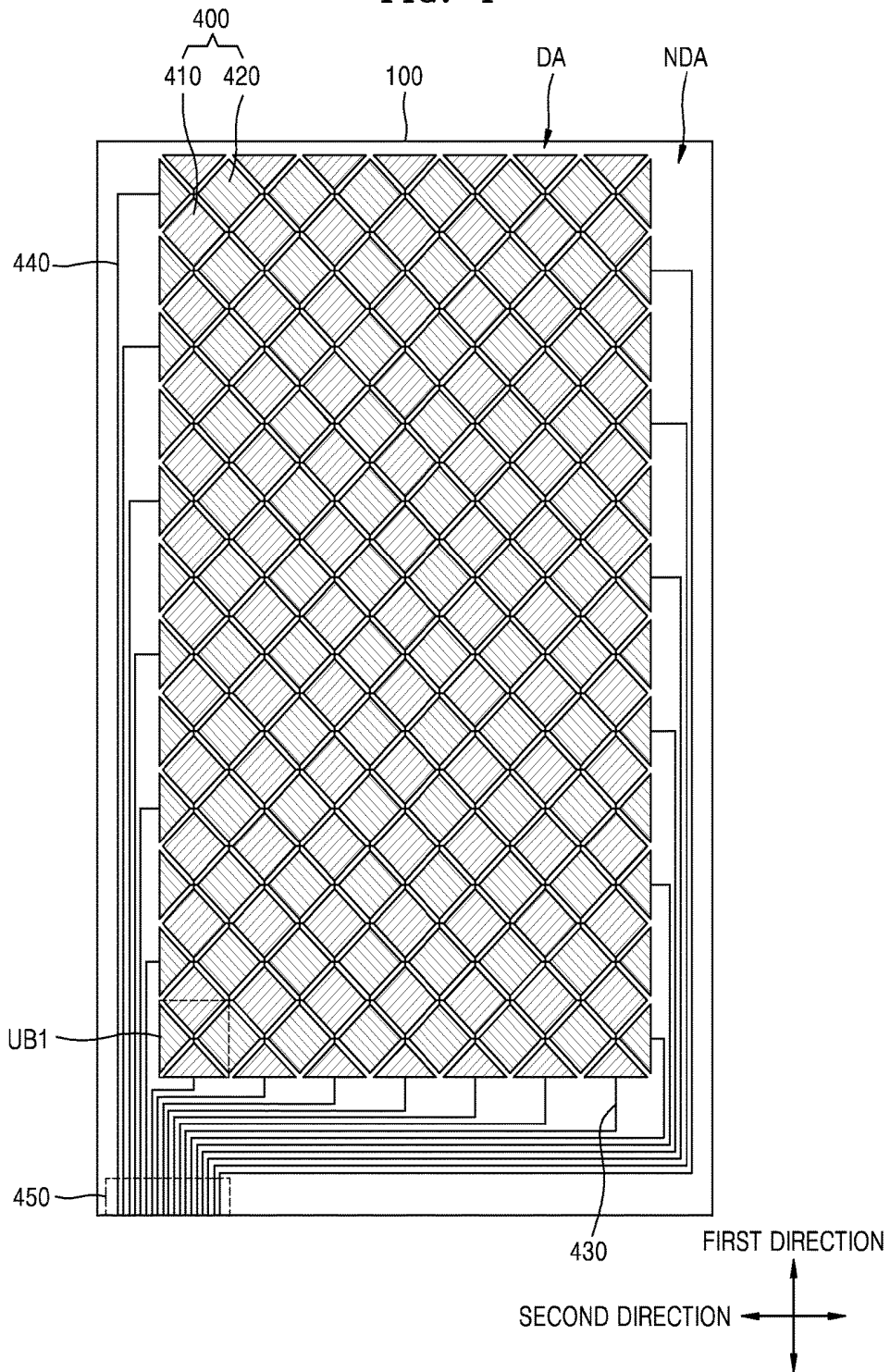
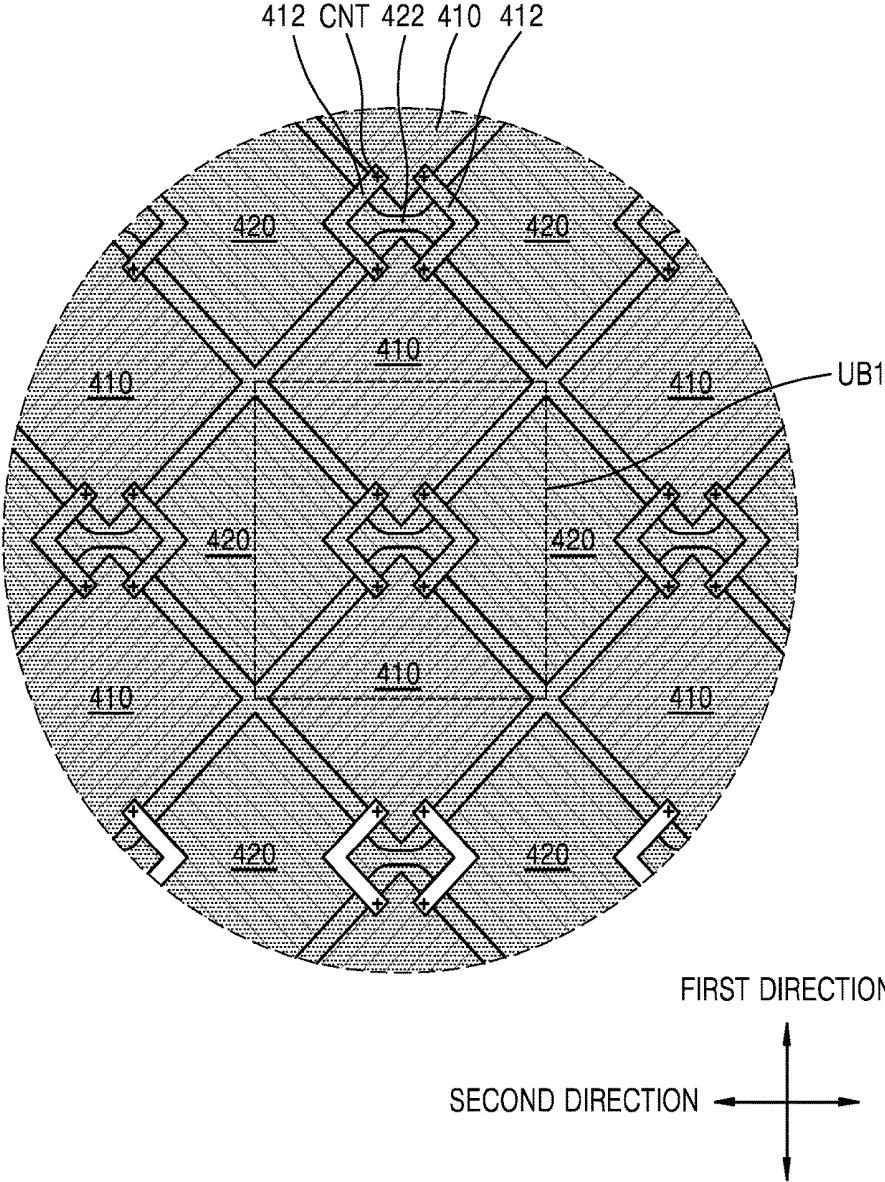

FIG. 5



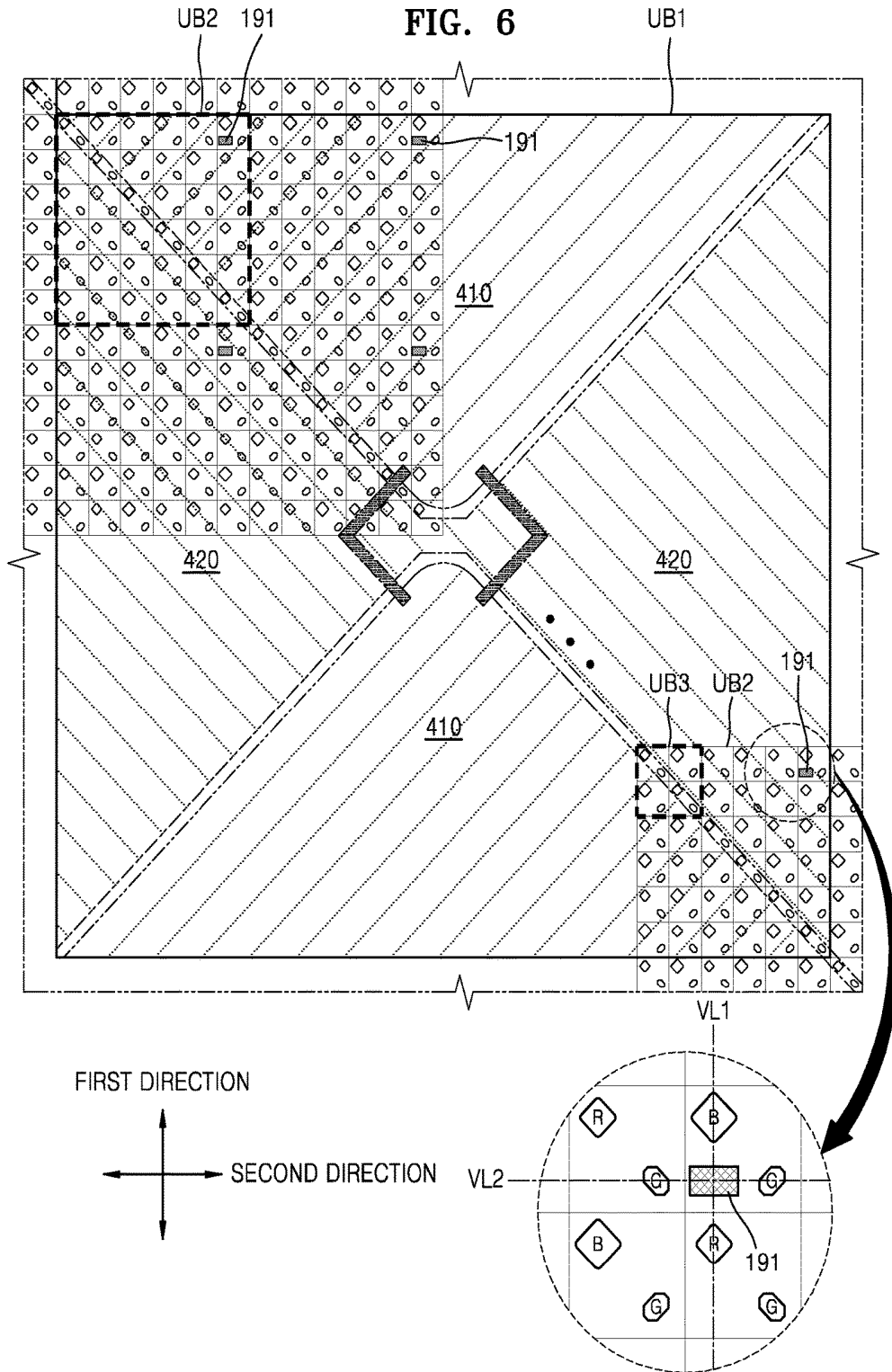

FIG. 7

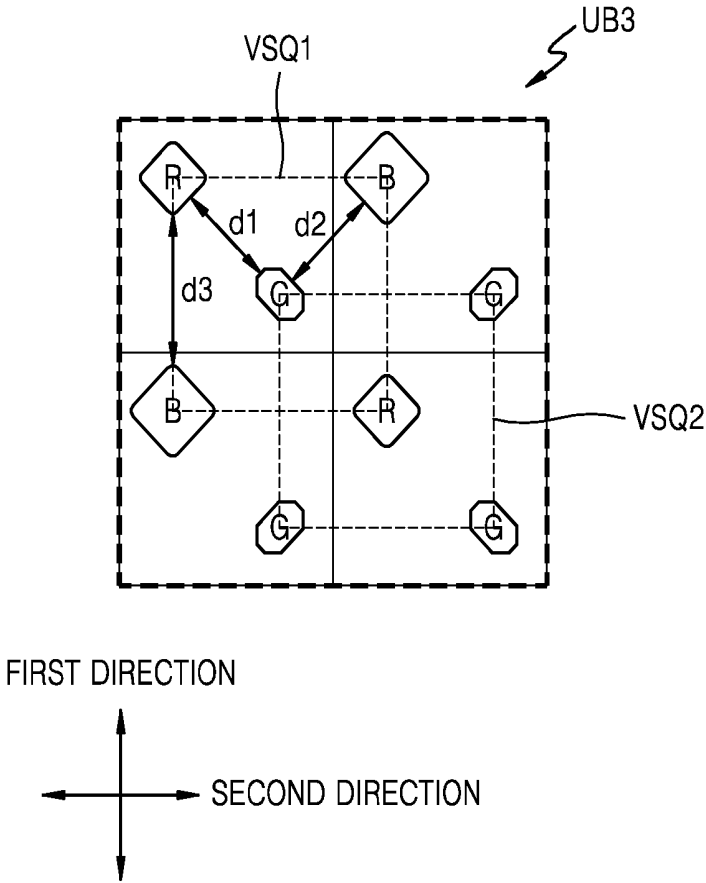

FIG. 8

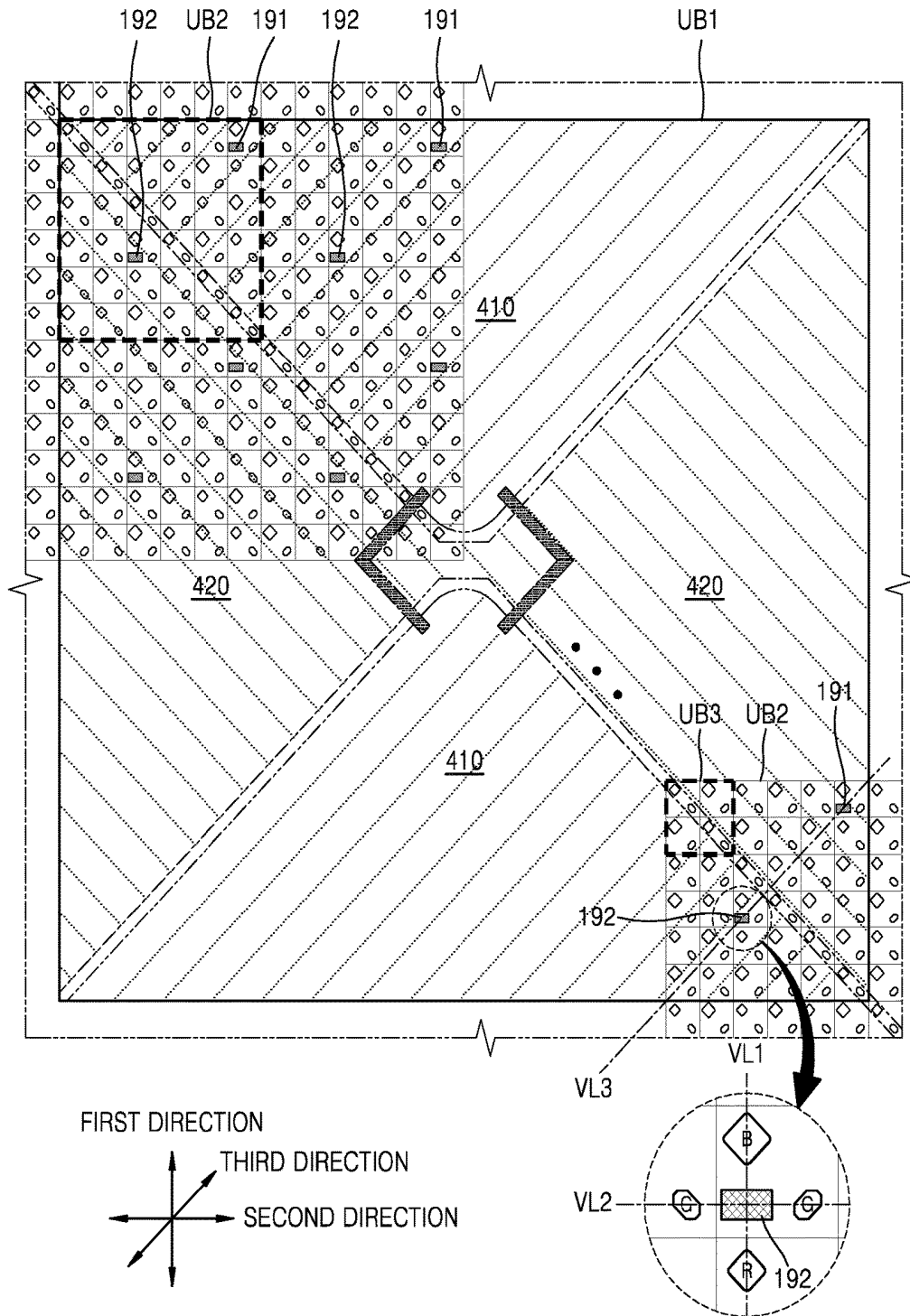

FIG. 9

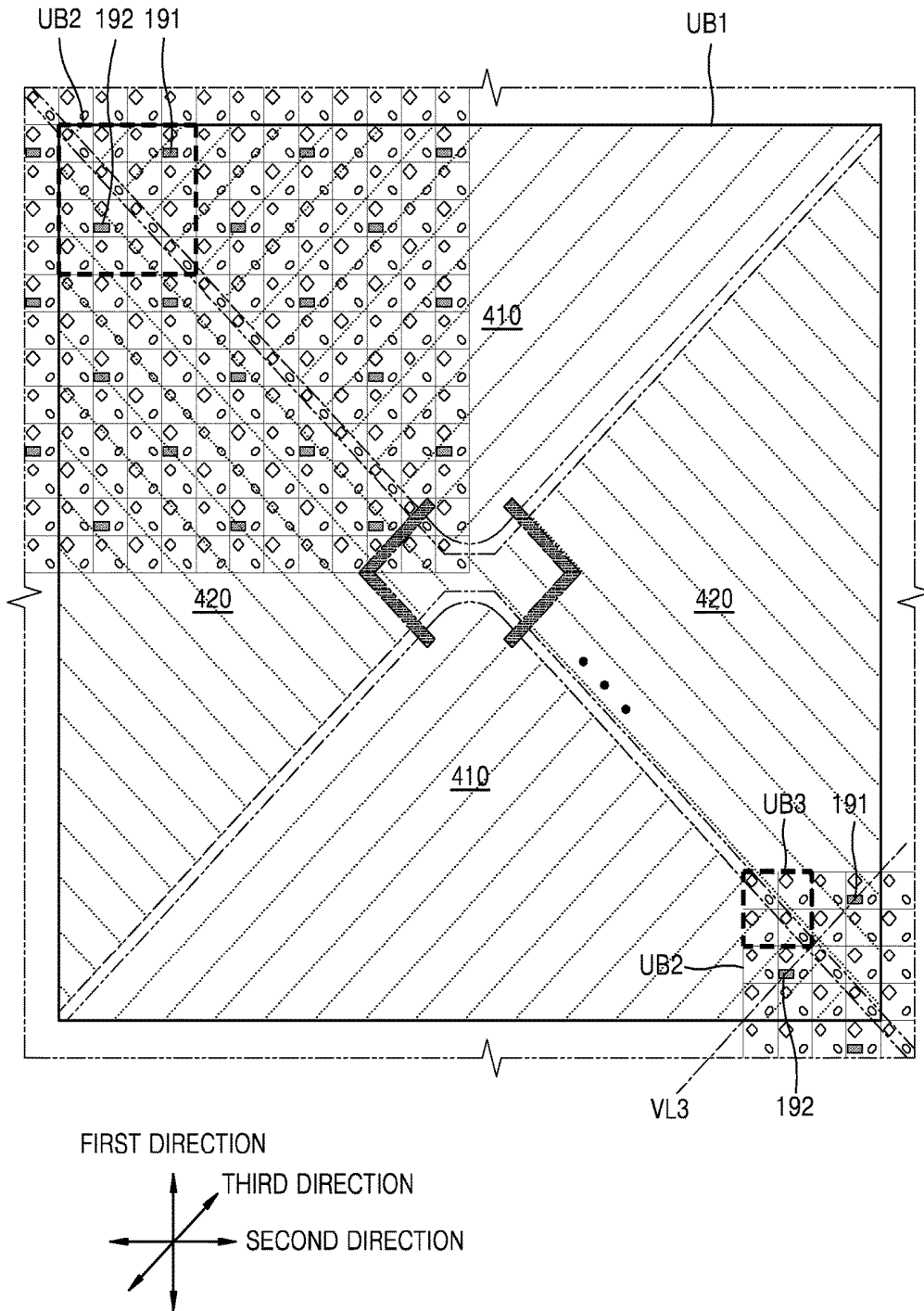
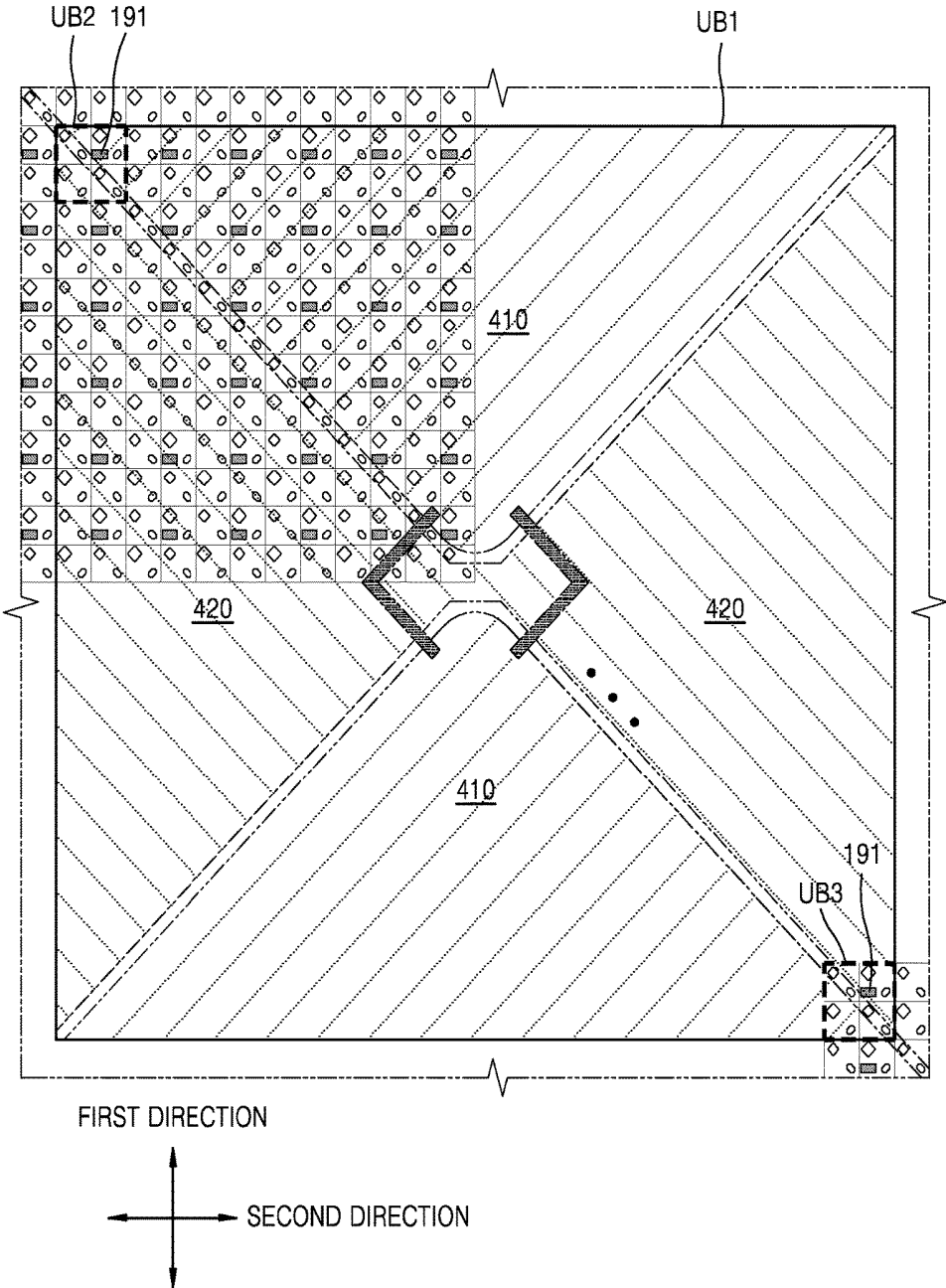
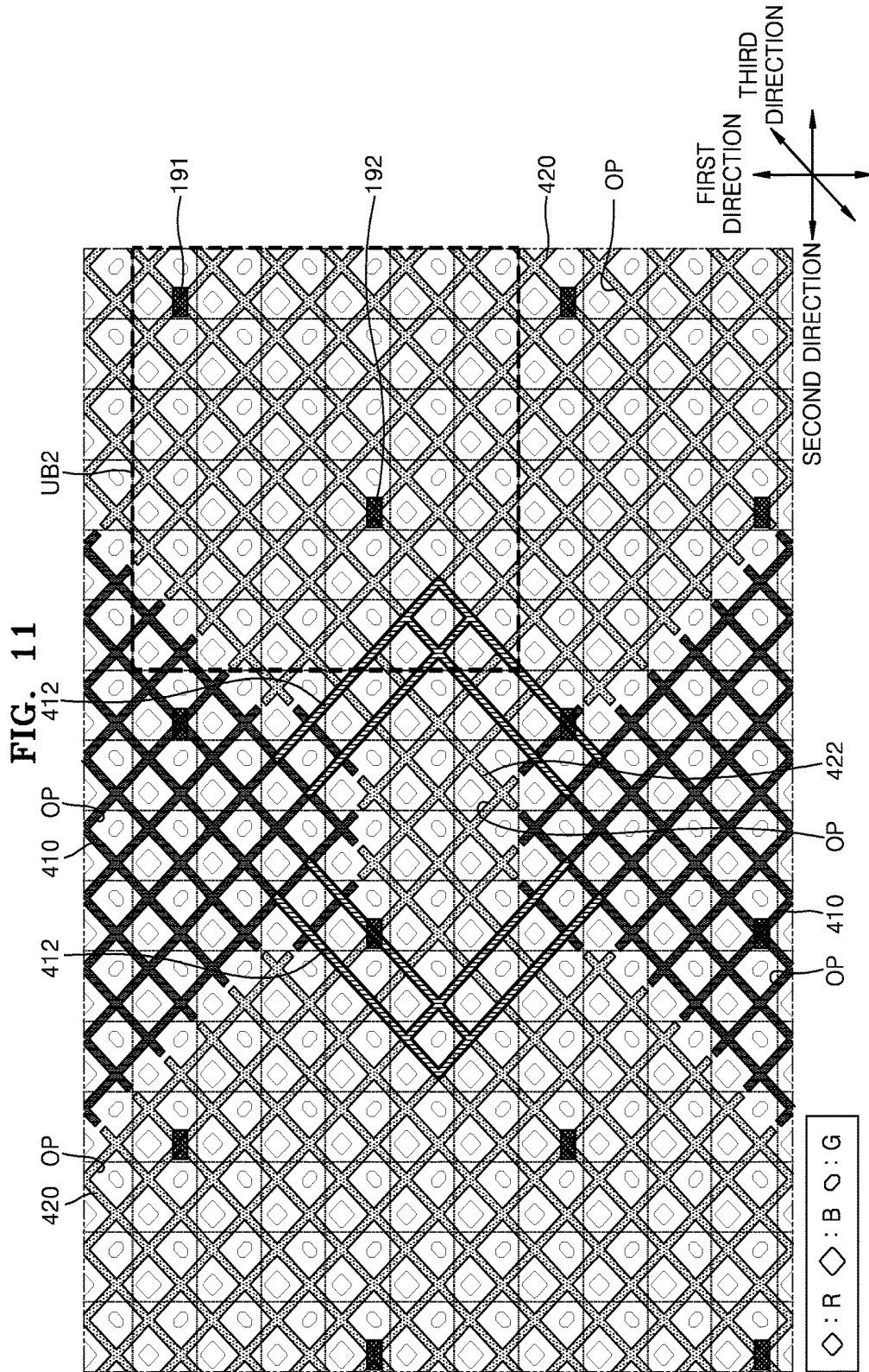

FIG. 10





## ORGANIC LIGHT EMITTING DISPLAY DEVICE

### CROSS-REFERENCE TO RELATED APPLICATION

[0001] This application claims priority to and the benefit of Korean Patent Application No. 10-2017-0041060, filed on Mar. 30, 2017, in the Korean Intellectual Property Office, the disclosure of which is incorporated by reference in its entirety herein.

### BACKGROUND

#### 1. Technical Field

[0002] One or more exemplary embodiments of the inventive concept relate to an organic light emitting display device.

#### 2. Discussion of the Related Art

[0003] An organic light emitting display device may include an organic light-emitting diode (OLED). An OLED is a light emitting diode in which the emissive electroluminescent layer is a film of an organic compound that emits light in response to an electric current. When the organic light emitting display device is implemented in a portable manner, the display device may include a touch function. For example, the display device may be configured to sense the location of a finger or a stylus of a user contacting a surface thereof.

[0004] The organic light emitting display device may include touch electrodes to support the touch function. An inspection may be performed to verify whether a defect is present in the touch electrodes. The inspection may include analyzing images of the touch electrodes captured by a camera.

### SUMMARY

[0005] According to an exemplary embodiment of the inventive concept, there is provided an organic light emitting display device including: a substrate including a plurality of pixel areas and a pixel separating area between the pixel areas; a plurality of pixels corresponding to each of the plurality of pixel areas, each of the pixels including a pixel electrode, an opposite electrode, and an organic light emitting layer disposed between the pixel electrode and the opposite electrode; a plurality of spacers disposed in the pixel separating area and spaced apart from each other; and a touch electrode unit disposed over the plurality of pixels and the plurality of spacers. The touch electrode unit includes first touch electrodes arranged in a first direction and second touch electrodes arranged in a second direction substantially perpendicular to the first direction. The touch electrode unit includes a plurality of touch pattern unit blocks repeatedly arranged and each touch pattern unit block includes portions of each of neighboring first touch electrodes and portions of each of neighboring second touch electrodes. An arrangement of the spacers of each touch pattern unit block corresponds to a plurality of spacer pattern unit blocks repeatedly arranged and each spacer pattern unit block includes at least one spacer and is smaller than the touch pattern unit block.

[0006] According to an embodiment, the plurality of pixels include a plurality of pixel pattern unit blocks repeatedly

arranged, and each pixel pattern unit block includes at least a first pixel, a second pixel, and a third pixel, and the first pixel, the second pixel, and the third pixel emit light corresponding to different colors.

[0007] According to an embodiment, an arrangement of the pixels of each spacer pattern unit block corresponds to K of the pixel pattern unit blocks arranged in the first direction, and L of the pixel pattern unit blocks arranged in the second direction, where K and L are natural numbers.

[0008] According to an embodiment, an arrangement of the pixels of each touch pattern unit block corresponds to M of the pixel pattern unit blocks arranged in the first direction, and N of the pixel pattern unit blocks arranged in the second direction, where M is a natural number and an integer multiple of the K, and N is a natural number and an integer multiple of the L.

[0009] According to an embodiment, in each pixel pattern unit block, the number of the third pixels is equal to a sum of the number of the first pixels and the number of the second pixels.

[0010] According to an embodiment, the at least one spacer is located at an intersection of a first virtual line connecting neighboring first pixels and second pixels, and a second virtual line connecting neighboring third pixels.

[0011] According to an embodiment, the at least one spacer includes a first spacer adjacent to a corner of each spacer pattern unit block.

[0012] According to an embodiment, each spacer pattern unit block further includes a second spacer separated apart from the first spacer in a third direction that forms an acute angle with respect to the first direction and the second direction.

[0013] According to an embodiment, each touch pattern unit block has a square shape.

[0014] According to an embodiment, each spacer pattern unit block has a square shape.

[0015] According to an exemplary embodiment of the inventive concept, provided is an organic light emitting display device including: a plurality of pixels, each pixel including a pixel electrode, an opposite electrode, and an organic light emitting layer between the pixel electrode and an opposite electrode; a plurality of spacers disposed between neighboring pixels and spaced apart from each other; and a touch electrode unit disposed over the plurality of pixels and the plurality of spacers. The touch electrode unit includes first touch electrodes arranged in a first direction and second touch electrodes arranged in a second direction perpendicular to the first direction. The touch electrode unit includes a plurality of touch pattern unit blocks repeatedly arranged and each touch pattern unit block includes portions of each of neighboring first touch electrodes and portions of each of neighboring second touch electrodes. The plurality of spacers includes a plurality of spacer pattern unit blocks repeatedly arranged and each spacer pattern unit block includes at least one spacer and is smaller than the touch pattern unit block.

[0016] According to an embodiment, each of the first touch electrodes and each of the second touch electrodes include wires of a net structure at least partially surrounding each of the plurality of pixels.

[0017] According to an embodiment, the plurality of spacers overlap the wires of the first touch electrodes or the wires of the second touch electrodes.

[0018] According to an embodiment, an arrangement of the spacers corresponding to each touch pattern unit block correspond to the arrangement of the spacers according to an  $A \times B$  array of the spacer pattern unit blocks, where  $A$  and  $B$  are natural numbers.

[0019] According to an embodiment, the plurality of pixels include a plurality of pixel pattern unit blocks repeatedly arranged, each pixel pattern unit block includes at least three pixels that emit light corresponding to different colors, and the arrangement of pixels of each spacer pattern unit block corresponds to  $K$  of the pixel pattern unit blocks arranged in the first direction or in the second direction, where  $K$  is a natural number.

[0020] According to an embodiment, the plurality of pixels include a plurality of pixel pattern unit blocks repeatedly arranged, each pixel pattern unit block includes at least three pixels that emit light corresponding to different colors, and the arrangement of the pixels of each touch pattern unit block corresponds to  $M$  of the pixel pattern unit blocks arranged in the first direction or in the second direction, where  $M$  is a natural number.

[0021] In this embodiment, the plurality of pixels include a first pixel, a second pixel, and a third pixel that emit light corresponding to different colors, and the at least one spacer is located at an intersection of a first virtual line connecting neighboring first pixels and second pixels, and a second virtual line connecting neighboring third pixels.

[0022] According to an embodiment, the at least one spacer includes a first spacer adjacent to one corner of each spacer pattern unit block.

[0023] According to an embodiment, each spacer pattern unit block further includes a second spacer spaced apart from the first spacer in a third direction crossing the first direction and the second direction.

[0024] According to an embodiment, each touch pattern unit block and each spacer pattern unit block have a square shape.

[0025] According to an exemplary embodiment of the inventive concept, an organic light emitting display device includes a substrate including a plurality of pixel areas and a pixel separating area between the pixel areas; a plurality of pixels corresponding to each of the plurality of pixel areas, each of the pixels including a pixel electrode, an opposite electrode, and an organic light emitting layer located between the pixel electrode and the opposite electrode; a plurality of spacers disposed in the pixel separating area and spaced apart from each other; and a touch electrode layer disposed over the plurality of pixels and the plurality of spacers. The touch electrode layer includes first touch electrodes and second touch electrodes arranged in a first direction, third touch electrodes and fourth touch electrodes arranged in a second other direction, a first connection line connecting the first and second touch electrodes together, and a second connection line connecting the third and fourth touch electrodes together, where the first direction is perpendicular to the second direction.

[0026] In an embodiment, a first spacer among the spacers is adjacently disposed between a first pixel, a second pixel, a third pixel, and a fourth pixel among the pixels, the first pixel emitting a first color, the second pixel emitting a second color, and the third and fourth pixels emitting a third color.

[0027] In an embodiment, wherein the first and second pixels are arranged on the first direction and the third and fourth pixels are arranged in the second direction.

#### BRIEF DESCRIPTION OF THE DRAWINGS

[0028] The inventive concept will become apparent and more readily appreciated from the following description of the embodiments thereof, taken in conjunction with the accompanying drawings in which:

[0029] FIG. 1 is a plan view of an organic light emitting display device according to an exemplary embodiment of the present inventive concept.

[0030] FIG. 2 is a sectional view taken along the line II-II in FIG. 1.

[0031] FIG. 3 is a cross-sectional view of a display unit, a sealing member, and a touch electrode unit formed on the substrate of FIG. 2 according to an exemplary embodiment of the present inventive concept.

[0032] FIG. 4 is a plan view of the touch electrode unit disposed over the substrate.

[0033] FIG. 5 is an enlarged plan view of a portion of FIG. 4.

[0034] FIG. 6 is a plan view of a portion of an organic light emitting display according to an exemplary embodiment of the present inventive concept.

[0035] FIG. 7 is a plan view of one pixel pattern unit block excerpted from FIG. 6.

[0036] FIG. 8 is a plan view of a portion of an organic light emitting display device according to an exemplary embodiment of the present inventive concept.

[0037] FIG. 9 is a plan view of a portion of an organic light emitting display device according to an exemplary embodiment of the present inventive concept.

[0038] FIG. 10 is a plan view of a portion of an organic light emitting display device according to an exemplary embodiment of the present inventive concept.

[0039] FIG. 11 is a plan view of a portion of a touch pattern unit block according to an exemplary embodiment of the present inventive concept.

#### DETAILED DESCRIPTION

[0040] As the inventive concept allows for various changes and numerous embodiments, exemplary embodiments will be illustrated in the drawings and described in detail in the written description. Effects and features of the present disclosure and methods of achieving them will be apparent with reference to the embodiments described below in detail with reference to the drawings. However, the present disclosure is not limited to the embodiments described below, but may be implemented in various forms.

[0041] Hereinafter, exemplary embodiments of the present inventive concept will be described in detail with reference to the accompanying drawings, wherein like reference numerals refer to like or corresponding components throughout the drawings and a duplicate description thereof will be omitted.

[0042] As used herein, the singular forms “a,” “an” and “the” are intended to include the plural forms as well, unless the context clearly indicates otherwise.

[0043] When a certain embodiment may be implemented differently, a specific process order may be performed differently from the described order. For example, two con-

secutively described processes may be performed substantially at the same time or performed in an order opposite to the described order.

[0044] FIG. 1 is a plan view of an organic light emitting display device 10 according to an exemplary embodiment of the present inventive concept. FIG. 2 is a sectional view taken along the line II-II in FIG. 1.

[0045] Referring to FIG. 1, the organic light emitting display device 10 includes a display area DA and a non-display area NDA. In the display area DA, pixels including display elements such as organic light emitting diodes (OLEDs) may be arranged to provide a certain image. The non-display area NDA is an area which does not provide an image and surrounds the display area DA. In the non-display area NDA, a scan driver and a data driver which provide electrical signals to be applied to the pixels in the display area DA, and power lines providing power such as a driving voltage and a common voltage may be arranged. The scan driver may apply gate signals to gate lines connected to the pixels and the data driver may provide data signals to data lines connected to the pixels.

[0046] As illustrated in FIG. 2, the organic light emitting display device 10 includes a display unit 200 forming the display area DA on a substrate 100. The substrate 100 may include various materials such as glass, metal, or plastic such as polyethylene terephthalate (PET), polyethylenenaphthalate (PEN), and polyimide. The display unit 200 may include pixels including OLEDs that are configured to provide a certain image. In an embodiment, the display unit 200 is covered by a sealing member 300.

[0047] The sealing member 300 may face the substrate 100 with the display unit 200 therebetween and protect the display unit 200 from external moisture or oxygen, or the like. In an embodiment, a touch electrode unit 400 is located on the sealing member 300.

[0048] The touch electrode unit 400 may include a plurality of touch electrodes having conductivity. For example, the touch electrode unit 400 may be of a capacitive type. In an embodiment, the touch electrode unit 400 outputs coordinates of a location at which an object approaches or touches, by using a change in capacitance occurring when the object such as a user's finger or a stylus approaches or touches a surface of the touch electrode unit 400.

[0049] In an embodiment of the inventive concept, an optical functional layer 500 is located on the touch electrode unit 400. In an embodiment of the inventive concept, the optical function layer 500 includes a polarizing plate or a polarizer. In an embodiment, the polarizer is an optical filter that lets light waves of a specific polarization pass and blocks light waves of other polarizations. In another exemplary embodiment, the optical function layer 500 includes a layer including a black matrix and a color filter. In an embodiment, the black matrix prevents light from passing therethrough. According to another exemplary embodiment, the optical functional layer 500 includes a window member. In an embodiment, the window member is transparent.

[0050] FIG. 3 is a cross-sectional view of the display unit 200, the sealing member 300, and the touch electrode unit 400 formed on the substrate 100 of FIG. 2 according to an exemplary embodiment of the present inventive concept.

[0051] Referring to FIG. 3, the display unit 200 is located on the substrate 100. The display unit 200 includes OLEDs 250R, 250B, and 250G provided for each pixel. The OLEDs

250R, 250B, and 250G may be electrically connected to their respective thin film transistors (TFTs) and storage capacitor (Cst).

[0052] In an embodiment, the TFT includes a semiconductor layer 120, a gate electrode 140 overlapping a portion (channel area) of the semiconductor layer 120, and a source electrode 160 and a drain electrode 162 connected to the semiconductor layer 120. The semiconductor layer 120 may include an inorganic semiconductor such as silicon, or an organic semiconductor or an oxide semiconductor material. The semiconductor layer 120 may include a source area, a drain area, and a channel area located between the source area and the drain area. According to an embodiment, an amorphous silicon layer is formed on the substrate 100, and is crystalized to be a polycrystalline silicon layer, and patterned. In an embodiment, a portion of the polycrystalline silicon layer which does not overlap the gate electrode 140 is doped with impurities by using a self-aligning mask on the gate electrode 140. As a result, the semiconductor layer 120 including the source area, the drain area, and the channel area therebetween may be formed. The gate electrode 140 may have a single layer or a multi-layer including at least one of Al, Pt, Pd, Ag, Mg, Au, Ni, Nd, Ir, Cr, Li, Ca, Mo, Ti, and/or W.

[0053] A buffer layer 110 for preventing infiltration of impurities may be located between the semiconductor layer 120 and the substrate 100. A gate insulating layer 130 may be located between the semiconductor layer 120 and the gate electrode 140. An interlayer insulating layer 150 may be located on the gate electrode 140. The buffer layer 110 may include an inorganic material such as silicon oxide ( $\text{SiO}_x$ ), silicon nitride ( $\text{SiN}_x$ ), silicon oxynitride ( $\text{SiON}$ ), aluminum oxide ( $\text{Al}_2\text{O}_3$ ), aluminum nitride (AlN), titanium oxide ( $\text{TiO}_2$ ), or titanium nitride (TiN). The gate insulating layer 130 may include a material such as  $\text{SiN}_x$  or  $\text{SiO}_x$ , and the interlayer insulating layer 150 may be a single layer or a multi-layer including a material such as  $\text{SiN}_x$ ,  $\text{SiO}_x$ , or SiON.

[0054] The source electrode 160 and the drain electrode 162 may be located on the interlayer insulating layer 150 and be connected to the source area and the drain area of the semiconductor layer 120, respectively. According to an embodiment, the source area and the drain area of the semiconductor layer 120 may be referred to as a source electrode and a drain electrode, respectively. The source electrode 160 and the drain electrode 162 may have a single layer or a multi-layer including at least one of Al, Pt, Pd, Ag, Mg, Au, Ni, Nd, Ir, Cr, Li, Ca, Mo, Ti, and/or W.

[0055] The storage capacitor Cst includes a bottom electrode 142 and a top electrode 164. The bottom electrode 142 (e.g., a lower electrode) may include the same material as the gate electrode 140, and the upper electrode 164 may include the same material as the source electrode 160 or the drain electrode 162. However, the inventive concept is not limited thereto.

[0056] The thin film transistor TFT and the storage capacitor Cst may be covered by a planarization insulating layer 170. The planarization insulating layer 170 may include  $\text{SiO}_2$ ,  $\text{SiN}_x$ , SiON,  $\text{Al}_2\text{O}_3$ ,  $\text{TiO}_2$ ,  $\text{Ta}_2\text{O}_5$ ,  $\text{HfO}_2$ ,  $\text{ZrO}_2$ , BST, or PZT. Alternatively, the planarization insulating layer 170 may include an organic insulating material such as a general purpose polymer (PMMA or PS), a polymer derivative having a phenolic group, an acrylic polymer, an imide polymer, an arylether polymer, an amide polymer, a fluorine

polymer, a p-xylene polymer, a vinyl alcohol-based polymer, and blends thereof. Alternatively, the planarization insulating layer **170** may include both the above-mentioned inorganic insulating material and organic insulating material.

**[0057]** The organic light emitting devices **250R**, **250B**, and **250G** corresponding to respective pixels may be located on the planarization insulating layer **170**. Each of the organic light emitting devices **250R**, **250B**, and **250G** may be electrically connected to the thin film transistor TFT via contact holes defined in the planarization insulating layer **170**. The organic light emitting devices **250R**, **250B**, and **250G** emit red color light, blue color light, and green color light, respectively.

**[0058]** The red color organic light emitting device **250R** includes a pixel electrode **210**, an organic light emitting layer **220R** emitting red color light, and an opposite electrode **230**, and may correspond to a first pixel emitting red color light. The blue color organic light emitting device **250B** includes the pixel electrode **210**, an organic light emitting layer **220B** emitting blue color light, and the opposite electrode **230**, and may correspond to a second pixel emitting blue color light. The green color organic light emitting device **250G** include the pixel electrode **210**, an organic light emitting layer **220G** emitting green color light, and the opposite electrode **230**, and may correspond to a third pixel emitting green color light. In this specification, it will be understood that the first, second, and third pixels represent red color, blue color, and green color sub-pixels, respectively.

**[0059]** The pixel electrode **210** may correspond to each pixel area PA and may be a reflective electrode. The pixel electrode **210** may include a reflective film including Ag, Mg, Al, Pt, Pd, Au, Ni, Nd, Ir, Cr, or a compound thereof, and may further include a layer located on the reflective film, including indium tin oxide (ITO), indium zinc oxide (IZO), zinc oxide (ZnO), or indium oxide ( $\text{In}_2\text{O}_3$ ). For example, the pixel electrode **210** may be a triple layer of ITO/Ag/ITO.

**[0060]** In an embodiment, the pixel defining layer **180** includes an opening exposing a central portion of the pixel electrode **210** to define the pixel (sub-pixel). In addition, an arc or the like may be prevented from occurring at an edge (end) of the pixel electrode **210** by increasing a distance between the edge of the pixel electrode **210** and the opposite electrode **230**. The pixel defining layer **180** may include an organic insulating material such as polyimide (PI) or hexamethyldisiloxane (HMDSO).

**[0061]** In an embodiment, a spacer **191** is located on the pixel defining layer **180**. For example, the spacer **191** may directly contact the pixel defining layer **180**. The spacer **191** may correspond to a pixel separating area DPA located between the pixel areas PA. The spacer **191** may prevent or minimize defects of the organic light emitting layers **220R**, **220B** and **220G** due to sagging of a mask, by supporting the mask to be used in a deposition process of the organic light emitting layers **220R**, **220B** and **220G** to be described below. Alternatively, the spacer **191** may prevent or minimize the Newton-ring phenomenon due to sagging or the like of a sealing substrate, by maintaining a gap between the substrate **100** and the sealing substrate constant, even when external pressure is applied to the sealing member **300** (for example, a rigid sealing substrate).

**[0062]** The spacer **191** may include the same material as the pixel electrode **180**. For example, the spacer **191** may

include an organic insulating material such as PI or HMDSO. The spacer **191** and the pixel defining layer **180** may be formed together in a same mask process, for example, in a process using a halftone mask.

**[0063]** The red color organic light emitting layer **220R** may include a fluorescent material or a phosphorescent material that emits red color visible light, the blue color organic light emitting layer **220B** may include a fluorescent material or a phosphorescent material that emits blue color visible light, and the green color organic light emitting layer **220G** may include a fluorescent material or a phosphorescent material that emits green color visible light.

**[0064]** In an embodiment, the opposite electrode **230** is a (semi-) transparent electrode. The opposite electrode **230** may be a layer including Ag, Mg, Al, Yb, Ca, Li, Au or a compound thereof, or a layer including a (semi-) transparent material such as ITO, IZO, ZnO or  $\text{In}_2\text{O}_3$ . According to an embodiment, the opposite electrode **230** includes a metal thin film including Ag or Mg. The opposite electrode **230** may be integrally formed to entirely cover both the pixel area PA and the pixel separating area DPA.

**[0065]** FIG. 3 illustrates a structure in which the red color, blue color, and green color organic light emitting layers **220R**, **220B**, and **220G** are between the pixel electrode **210** and the opposite electrode **230** in direct contact with them. However, the inventive concept is not limited thereto. According to an exemplary embodiment, the red color, blue color, and green color organic light emitting layers **220R**, **220B**, and **220G** include a first functional layer thereunder and a second functional layer thereon. Each of the first and/or second functional layers, like the opposite electrode **230**, may be integrally formed to entirely cover both the pixel area PA and the pixel separating area DPA.

**[0066]** The first functional layer may be a single layer or a multi-layer including a hole injection layer (HIL) and/or a hole transport layer (HTL). For example, when the first functional layer includes a polymer material, the first functional layer may be a single HTL including poly-(3,4)-ethylene-dihydroxythiophene (PEDOT) or polyaniline (PANI). When the first functional layer includes a low molecular weight material, the first functional layer may include the HIL and the HTL.

**[0067]** The second functional layer may include a single layer or a multi-layer including an electron transport layer (ETL) and/or an electron injection layer (EIL). The second functional layer may be omitted. For example, when the first functional layer and the organic light emitting layers **220R**, **220B**, and **220G** include polymer materials, the second functional layer may be omitted. When the first functional layer and the organic light emitting layers **220R**, **220G**, and **220B** include low molecular weight materials, the second functional layer may be additionally formed for improving the characteristics of an organic light emitting device. In this case, the second functional layer may include the ETL and/or the EIL.

**[0068]** The sealing member **300** may include at least one inorganic layer and at least one organic layer. In an embodiment, the sealing member **300** includes a first inorganic layer **310**, a second inorganic layer **330**, and an organic layer **320** located between the first inorganic layer **310** and the second inorganic layer **330**. The first and second inorganic layers **310** and **330** may include  $\text{SiO}_x$ ,  $\text{SiN}_x$ , or SiON. The organic layer **320** may include at least one of polyethylene terephthalate, polyethylene naphthalate, polycarbonate,

polyimide, polyethylene sulfonate, polyoxymethylene, polyarylate, and/or hexamethyldisiloxane. Although not illustrated, other layers such as a capping layer may be located between the first inorganic layer 310 and the opposite electrode 230 as needed. A case is described in which the sealing member 300 includes the first inorganic layer 310, the organic layer 320, and the second inorganic layer 330 which are sequentially stacked, according to an embodiment. However, the number of stacking times may be changed such that inorganic layers and organic layers are alternately stacked. According to an embodiment, a case is described in which the sealing member 300 is a thin film sealing film including alternately stacked inorganic layers and organic layers. However, according to another embodiment, the sealing member 300 may be a rigid translucent sealing substrate.

[0069] In an embodiment, the touch electrode unit 400 is located on the sealing member 300 and generates location information in accordance with a touch input. A structure of the touch electrode unit 400 will be described below with reference to FIGS. 4 and 5.

[0070] FIG. 4 is a plan view of the touch electrode unit 400 over the substrate 100. FIG. 5 is an enlarged plan view of an excerpt of a portion of FIG. 4.

[0071] Referring to FIG. 4, the touch electrode unit 400 (e.g., a touch electrode layer) includes first touch electrodes 410 arranged in a first direction and second touch electrodes 420 arranged in a second direction crossing (e.g. perpendicular to) the first direction.

[0072] The first touch electrodes 410 and the second touch electrodes 420 may be alternately arranged with each other. For example, the first touch electrodes 410 may be arranged in parallel with each other, with corners thereof meeting each other, in the first direction, and the second touch electrodes 420 may be arranged in parallel with each other between the first touch electrodes 410, with corners thereof meeting each other, in the second direction.

[0073] In an embodiment, the first touch electrodes 410 arranged in the first direction are electrically connected to each other, and the second touch electrodes 420 arranged in the second direction are electrically connected to each other. For example, as illustrated in FIG. 5, the first touch electrodes 410 may be electrically connected to each other via a first connection line 412, and the second touch electrodes 420 may be electrically connected to each other via a second connection line 422.

[0074] The first and second touch electrodes 410 and 420 may be located on the same layer and include the same materials. The second connection line 422 connecting the neighboring second touch electrodes 420 may be located on the same layer as the second touch electrodes 420 and include the same material as the second touch electrodes 420. In an embodiment, the second touch electrodes 420 and the second connection line 422 are integrally formed, and the first touch electrodes 410 are electrically connected to each other via the first connection line 412 thereon with an insulating layer (not illustrated) therebetween. In an embodiment, an insulating layer is located between a first connection line 412 and an overlapping second connection line 422 to prevent them from contacting one another. The first connection line 412 may be connected to respective first touch electrodes 410 via contact holes CNT penetrating the insulating layer. The first and second touch electrodes 410 and 420, and the first and second connection lines 412 and

422 may include a transparent conductive layer such as ITO, IZO, or ZnO, or may include a (semi-)transparent metal layer.

[0075] In an embodiment, columns of the first touch electrodes 410 in the first direction and rows of the second touch electrodes 420 in the second direction are respectively connected to sensing lines 430 and 440, as illustrated in FIG. 4. Signals obtained via the sensing lines 430 and 440 may be provided via a pad 450 to a circuit unit (not illustrated) including a location detection circuit. The location detection circuit may analyze voltages on the sensing lines 430 and 440 to detect the location at which a user touched the touch electrode unit 400. In an embodiment, the touch electrodes 410 and 420 are capacitive sensors.

[0076] The touch electrode unit 400 may be formed in a repetitive arrangement of certain touch pattern unit blocks UB1, as illustrated in FIGS. 4 and 5. The touch pattern unit block UB1 may be a virtual unit block having a certain area including at least portions of neighboring first touch electrodes 410 and at least portions of neighboring second touch electrodes 420, and may be understood as a minimum repetitive unit of array patterns of the first and second touch electrodes 410 and 420. Alternatively, the touch pattern unit block UB1 may be understood as a minimum unit of image capturing for defect inspection of the touch electrode unit 400. The defect of the touch electrode unit 400 may be detected by capturing the image corresponding to the touch pattern unit block UB1 for each area and comparing images. In this case, the minimum unit of image capture for defect inspection may correspond to the touch pattern unit block UB1.

[0077] In an embodiment, a shape of the touch pattern unit block UB1 is a quadrangle, for example, a square. For example, the touch pattern unit block UB1 may be a square having a length of less than about 5 mm in the first and second directions. When the touch electrode unit 400 is formed in the repetitive arrangement of square touch pattern unit blocks UB1 having a certain area while including a portion of the first touch electrodes 410 and a portion of the second touch electrodes 420, the location detection may be executed at a relatively fast response speed and the accuracy of the location detection may be improved.

[0078] FIG. 6 is a plan view of a portion of the organic light emitting display device 10 according to an exemplary embodiment of the present inventive concept and illustrates an arrangement of the first and second touch electrodes 410 and 420, the spacers 191, and first, second, and third pixels R, G, and B. FIG. 7 is a plan view of one pixel pattern unit block excerpted from FIG. 6.

[0079] As shown in FIG. 6, the spacers 191 and the first, second, and third pixels R, B, and G included in the organic light emitting display device 10 may be arranged by a certain rule.

[0080] An arrangement of the spacers 191 included in the organic light emitting display device 10 will be described below.

[0081] The spacers 191 of the organic light emitting display device include a plurality of spacer pattern unit blocks UB2 repeatedly arranged. The spacers 191 may be formed in a repetitive arrangement of spacer pattern unit blocks UB2. The spacer pattern unit block UB2 may be a virtual unit block having a certain area including at least one spacer 191 and may be understood as a minimum repetitive

unit of the arrangement pattern of the spacers **191** included in the organic light emitting display device **10**.

**[0082]** At least one spacer **191** of the spacer pattern unit block **UB2** may be arranged at a particular location in the spacer pattern unit block **UB2**. FIG. **6** illustrates an embodiment where the spacer pattern unit block **UB2** includes one spacer **191** and the one spacer **191** is adjacent to one corner of the spacer pattern unit block **UB2**.

**[0083]** The spacer **191** may be located between adjacent pixels, as illustrated in the enlarged view of FIG. **6**. For example, the spacer **191** may be located at a crossing point of a first virtual line **VL1** connecting neighboring first and second pixels **R** and **B**, and a second virtual line **VL2** connecting neighboring third pixels **G**. For example, the spacer **191** may be adjacently located between first and second pixels **R** and **B** and a pair of third pixels **G**.

**[0084]** In an embodiment, the spacer pattern unit block **UB2** is a virtual unit block having a smaller size than the touch pattern unit block **UB1**, and each touch pattern unit block **UB1** corresponds to the repetitive arrangement of the spacer pattern unit blocks **UB2**. For example, the arrangement of the spacers **191** of each touch pattern unit block **UB1** may be the same as the arrangement of the spacers **191** of the spacer pattern unit blocks **UB2** repeatedly arranged, as illustrated in FIG. **6**.

**[0085]** For example, when each touch pattern unit block **UB1** corresponds to the arrangement of the spacer pattern unit blocks **UB2** in an  $A \times B$  array ( $A$  and  $B$  are natural numbers), the arrangement pattern of the spacers **191** corresponding to each touch pattern unit block **UB1** may correspond to the arrangement pattern of the spacers **191** when the spacer pattern unit blocks **UB2** are arranged in the  $A \times B$  array. In the present specification, “the spacer pattern unit blocks **UB2** are arranged in the  $A \times B$  array” may denote “a matrix array in which a number  $A$  of the spacer pattern unit blocks **UB2** are arranged in the first direction and a number  $B$  of the spacer pattern unit blocks **UB2** are arranged in the second direction”. When the touch pattern unit block **UB1** is a square and the spacer pattern unit block **UB2** is a square, the above-described  $A$  and  $B$  have the same values.

**[0086]** When the arrangement of the spacers **191** corresponding to each touch pattern unit block **UB1** does not correspond to the repetitive arrangement of the spacer pattern unit blocks **UB2**, the arrangements of the spacers **191** of each touch pattern unit block **UB1** will be different from each other. For example, an arrangement pattern of the spacers **191** in any one of the neighboring touch pattern unit blocks **UB1s** may be different from the arrangement pattern of the spacers **191** in the other one of the neighboring touch pattern unit blocks **UB1s**. A defect inspection of the touch electrode unit **400** (refer to FIG. **2**) may be performed by capturing an image for each touch pattern unit block **UB1** and comparing the captured images with one another or with a reference image. When the arrangement patterns of the spacers **191** are different in each touch pattern unit block **UB1**, interference fringes due to the spacers **191** may be different from each other and the images may be distorted. Thus, it may be impossible to detect the defect of the touch electrode unit **400**. However, according to an embodiment of the present inventive concept, since the arrangement of the spacers **191** of each touch pattern unit block **UB1** corresponds to the repetitive arrangement of the spacer pattern unit blocks **UB2** including the spacer **191** at particular location, the arrangement of the spacers **191** may be the

same for each touch pattern unit block **UB1**, and problems due to the interference described above at the defect inspection of the touch electrode unit **400** may be prevented or reduced.

**[0087]** An arrangement of the first, second, and third pixels **R**, **B**, and **G** included in the organic light emitting display device **10** will be described below.

**[0088]** The pixels of the organic light emitting display device **10**, for example, the first, second, and third pixels **R**, **B**, and **G**, may be formed in a repetitive arrangement of certain pixel pattern unit blocks **UB3s**. The pixel pattern unit block **UB3** may be a virtual unit block having a certain area including the first pixel **R**, the second pixel **B**, and the third pixel **G**. It may be understood that the pixel pattern unit block **UB3** corresponds to the minimum repetitive unit of the arrangement pattern of pixels included in the organic light emitting display device **10**. In an embodiment, the pixel pattern unit block **UB3** has a square shape.

**[0089]** In an embodiment, the pixel pattern unit block **UB3** includes the first, second, and third pixels **R**, **B**, and **G**, and the sum of the numbers of the first and second pixels **R** and **B** is the same as the number of the third pixels **G**. FIGS. **6** and **7** illustrate the pixel pattern unit block **UB3** including two first pixels **R**, two second pixels **B**, and four third pixels **G**.

**[0090]** The first, second, and third pixels **R**, **B**, and **G** may be at particular locations in the pixel pattern unit block **UB3**. As illustrated in FIG. **7**, the first pixel **R** and the second pixel **B** may be respectively placed at vertices of a first virtual rectangle **VSQ1** having one of the third pixels **G** as a center point. For example, the first pixels **R** may be respectively located at opposite vertices of a first virtual rectangle **VSQ1** with the third pixel **G** therebetween in a diagonal direction. The second pixels **B** may be respectively located at opposite vertices of the first virtual rectangle **VSQ1** with the third pixel **G** therebetween in the diagonal direction. The third pixels **G** may be respectively located at opposite vertices of the second virtual rectangle **VSQ2** centering on a pixel (the first pixel or the second pixel) at any one vertex of the first virtual rectangle **VSQ1**.

**[0091]** In an embodiment, the size of the first virtual rectangle **VSQ1** is the same as that of the second virtual rectangle **VSQ2**. Accordingly, the distances (the shortest distances) between the neighboring first and second pixels **R** and **B** in the first and second directions may be equal to each other, and the distances (the shortest distances) between the neighboring third pixels **G** in the first and second directions may be equal to each other. In an embodiment, a shortest distance  $d1$  between the first pixel **R** and the third pixel **G**, and a shortest distance  $d2$  between the second pixel **B** and the third pixel **G** are equal to each other, but smaller than a shortest distance  $d3$  between the first pixel **R** and the second pixel **B**.

**[0092]** In an embodiment, the pixel pattern unit block **UB3** is a virtual unit block having a smaller size than the touch pattern unit block **UB1**, and each touch pattern unit block **UB1** may correspond to the repetitive arrangement of the pixel pattern unit block **UB3**. For example, the arrangement of the pixels corresponding to each touch pattern unit block **UB1** may correspond to the repetitive arrangement of the pixel pattern unit blocks **UB3s** as illustrated in FIG. **6**.

**[0093]** In an embodiment, the size (area) of each touch pattern unit block **UB1** corresponds to the size (area) of a set of pixel pattern unit blocks **UB3s** arranged in an  $M \times N$  array

(M and N are natural numbers), and the arrangement pattern of the pixels of each touch pattern unit block UB1 correspond to the arrangement pattern of the pixels when the pixel pattern unit blocks UB3s are arranged in the M×N array (M and N may be the same numbers or different numbers).

[0094] In an embodiment, the pixel pattern unit block UB3 is a virtual unit block having a smaller size than the spacer pattern unit block UB2. Each spacer pattern unit block UB2 may correspond to the repetitive arrangement of the pixel pattern unit blocks UB3s. For example, the arrangement of the pixels of each spacer pattern unit block UB2 may correspond to the repetitive arrangement of the pixel pattern unit blocks UB3s.

[0095] In an embodiment, the size (area) of each spacer pattern unit block UB2 corresponds to the size (area) of a set of pixel pattern unit blocks UB3s arranged in a K×L array (K and L are natural numbers). In this case, the arrangement pattern of the pixels of each spacer pattern unit block UB2 may correspond to the arrangement pattern of the pixels when the pixel pattern unit blocks UB3s are arranged in the K×L array (K and L are natural numbers, and K and L may be the same numbers or different numbers). In FIG. 6, each spacer pattern unit block UB2 is illustrated as corresponding to a 3×3 array of the pixel pattern unit block UB3, as an example.

[0096] From an aspect of the arrangement of the spacers 191, the touch pattern unit block UB1 may correspond to the repetitive arrangement of the spacer pattern unit blocks UB2 as described above. In an embodiment, when the touch pattern unit block UB1 and the spacer pattern unit block UB2 are respectively squares, the arrangement of the spacers 191 in each touch pattern unit block UB1 may correspond to arrangement of the spacers 191 in the spacer pattern unit blocks UB2 when the spacer pattern unit blocks UB2 are arranged in, for example, an array of 15×15, or 20×20, or the like.

[0097] Similarly, from an aspect of pixel arrangement, the touch pattern unit block UB1 and the spacer pattern unit block UB2 may correspond to the repetitive arrangement of the pixel pattern unit blocks UB3s. In an embodiment, when each spacer pattern unit block UB2 corresponds to a 3×3 array of the pixel pattern unit blocks UB3s and each touch pattern unit block UB1 corresponds to a 15×15 array of the spacer pattern unit blocks UB2, the arrangement of the pixels of each touch pattern unit block UB1 may correspond to the arrangement of the pixels when the pixel pattern unit blocks UB3s are arranged in a 45×45 array.

[0098] FIG. 8 is a plan view of a portion of the organic light emitting display device according to another exemplary embodiment of the present inventive concept, and illustrates arrangements of the first and second touch electrodes 410 and 420, the first and second spacers 191 and 192, and the first, second, and third pixels R, B, and G. Since a configuration of the touch pattern unit block UB1 of FIG. 8 is similar to that described above with reference to FIGS. 6 and 7, differences will be mainly described below.

[0099] Referring to FIG. 8, the spacer pattern unit block UB2 may include a plurality of spacers, for example, a first spacer 191 and a second spacer 192.

[0100] The first spacer 191 may be placed adjacent to one corner of the spacer pattern unit block UB2 as described above with reference to FIG. 6. In an embodiment, the second spacer 192 is spaced apart from the first spacers 191 by a certain distance. For example, the first spacer 191 and

the second spacer 192 may be spaced apart from each other along a third virtual line VL3 extending in a third direction. The second spacer 192 may be placed adjacent to other corner of the spacer pattern unit block UB2 in the third direction. The third direction may be in an acute angle with respect to the first direction and the second direction, and may correspond to a diagonal direction of the spacer pattern unit block UB2.

[0101] Referring to an enlarged view in FIG. 8, the second spacer 192, like the first spacer 191, is placed at a point where the first virtual line VL1 connecting the neighboring first and second pixels R and B, and the second virtual line VL2 connecting the neighboring third pixels G cross each other.

[0102] FIG. 9 is a plan view of a portion of the organic light emitting display device according to another exemplary embodiment of the present inventive concept, and illustrates arrangements of the first and second touch electrodes 410 and 420, the first and second spacers 191 and 192, and the first, second, and third pixels R, B, and G. Since a configuration of the touch pattern unit block UB1 of FIG. 9 is similar to that described above with reference to FIGS. 6 and 7, differences will be mainly described below.

[0103] The pixel arrangement of the spacer pattern unit block UB2 may include the repetitive arrangement of the pixel pattern unit blocks UB3s. For example, the pixel arrangement of the spacer pattern unit block UB2 may correspond to that of a 2×2 array of the pixel pattern unit blocks UB3s as illustrated in FIG. 9. The first and second spacers 191 and 192 may be arranged in each spacer pattern unit block UB2, and the first and second spacers 191 and 192 may be arranged along the third virtual line VL3 in the third direction as described above with reference to FIG. 8.

[0104] FIG. 10 is a plan view of a portion of the organic light emitting display device according to an exemplary embodiment of the present inventive concept, and illustrates arrangements of the first and second touch electrodes, spacers, and pixels. Since a configuration of the touch pattern unit block UB1 of FIG. 10 is similar to that described above with reference to FIGS. 6 and 7, differences will be mainly described below.

[0105] Referring to FIG. 10, the spacer pattern unit block UB2 is smaller than the touch electrode unit block UB1, but is the same size as the pixel pattern unit block UB3. For example, the spacer pattern unit block UB2 and the pixel pattern unit block UB3 may be substantially the same unit blocks.

[0106] FIG. 11 is a plan view of a portion of the touch pattern unit block UB1 according to an exemplary embodiment of the present inventive concept. FIG. 11 may be understood as an enlarged view of a portion where the first touch electrode 410 and the second touch electrode 420 intersect each other in FIG. 8.

[0107] Referring to FIG. 11, the first and second spacers 191 and 192 are located between the first, second, and third pixels R, B, and G. The spacer arrangement of the organic light emitting display device may correspond to the repetitive arrangement of the spacer pattern unit blocks UB2 including the first and second spacers 191 and 192 which are spaced apart from each other in the third direction. The pixel arrangement of the organic light emitting display device may correspond to the repetitive arrangement of the pixel pattern unit blocks UB3s described above with reference to FIG. 7.

[0108] The first touch electrodes **410** are spaced apart from each other in the first direction and are electrically connected to each other via the first connection line **412**. The second touch electrodes **420** are arranged in the second direction and are electrically connected to each other via the second connection line **212** between the neighboring second touch electrodes **420**. The first connection line **412** may be placed on the first touch electrodes **410** with an insulating layer therebetween, and may electrically connect the first touch electrodes **410** via contact holes passing through the insulation layer. The second connection line **422** may be placed on a same layer as the second touch electrodes **420** and electrically connect the second touch electrodes **420** as described above.

[0109] In an embodiment, each of the first and second touch electrodes **410** and **420** include wires formed to at least partially surround the first through third pixels R, B, and G. The wires may have a net structure in which they are connected to each other but do not overlap the first through third pixels R, B, and G. The wires of each of the first and second touch electrodes **410** and **420** may at least partially surround each pixel.

[0110] In an embodiment, the wires of a first touch electrode **410** includes first wires that are parallel to one another that are connected to one another via second wires that are parallel to one another and perpendicular to the first wires. In an embodiment, the wires of a second touch electrode **420** include third wires that are parallel to one another that are connected to one another via fourth wires that are parallel to one another and perpendicular to the third wires. In an embodiment, the first wires are perpendicular to the third wires. In an embodiment, a first connection line **412** has an L shape (or a V shape) that connects the wires of a pair of first touch electrodes **410** together. In an embodiment, the L shape (or V shape) overlaps a portion of a second touch electrode **420**. In an embodiment, the pair of first touch electrodes **410** are connected together via a pair of the L shaped (or V shaped) connection lines, and the pair of second touch electrodes **420** are connected together via the second connection line **422**. In an embodiment, the first L shape (or V shape) of the pair of L shapes overlaps a portion of a second touch electrode **420** of the pair of second touch electrodes **420** and the second L shape (or V shape) of the pair of L shapes (or V shapes) overlaps a portion of another adjacent second touch electrode **420** of the pair of electrodes **420**.

[0111] Although the first and second touch electrodes **410** and **420** include transparent electrodes such as ITO, the transmittance may be less than about 100%. Thus, when the first, second, and third pixels R, B, and G overlap the wires of the first and second touch electrodes **410** and **420**, intensity of light of the red color, blue color, and green color, respectively emitted from the first, second, and third pixels R, B, and G may be reduced while the light passes through the wires. However, according to an embodiment of the present inventive concept, each of the first and second touch electrodes **410** and **420** have openings OP corresponding to the first, second, and third pixels R, B and G, and are formed in a net structure which at least partially surrounds the first, second, and third pixels R, B, and G. Thus, a problem of reduction in luminous efficiency due to the first and second touch electrodes **410** and **420** may be prevented.

[0112] The first and second connection lines **412** and **422** may have the same structure as the first and second touch

electrodes **410** and **420**. For example, each of the first and second connection lines **412** and **422** may have a net structure which at least partially surrounds each of the first, second, and third pixels R, B, and G, and may include openings OP exposing the first, second, and third pixels R, B, and G.

[0113] As described above, the first and second touch electrodes **410** and **420**, and the first and second connection lines **412** and **422** may have a wire structure which at least partially surrounds the first, second, and third pixels R, B and G. Thus, the wires, and the first and second spacers **191** and **192** may overlap each other in a non-pixel area.

[0114] As described above, the first and second touch electrodes **410** and **420** may include transparent electrodes such as ITO. However, the inventive concept is not limited thereto. In another embodiment of the inventive concept, the first and second touch electrodes **410** and **420**, and the first and second connection lines **412** and **422** include metal such as Ti, and /or Al.

[0115] Even when the organic light emitting display device as a display device having flexibility is bent or curled around a certain axis as the center, since the first and second touch electrodes **410** and **420** have the net structure as described above, broken or damaged wires may be prevented or reduced.

[0116] While one or more embodiments of the inventive concept have been described with reference to the figures, it will be understood by those of ordinary skill in the art that various changes in form and details may be made therein without departing from the spirit and scope of the inventive concept.

What is claimed is:

1. An organic light emitting display device comprising:
  - a substrate including a plurality of pixel areas and a pixel separating area between the pixel areas;
  - a plurality of pixels corresponding to each of the plurality of pixel areas, each of the pixels including a pixel electrode, an opposite electrode, and an organic light emitting layer disposed between the pixel electrode and the opposite electrode;
  - a plurality of spacers disposed in the pixel separating area and spaced apart from each other; and
  - a touch electrode unit disposed over the plurality of pixels and the plurality of spacers, the touch electrode unit including first touch electrodes arranged in a first direction and second touch electrodes arranged in a second direction perpendicular to the first direction, wherein:
    - the touch electrode unit includes a plurality of touch pattern unit blocks repeatedly arranged and each touch pattern unit block includes portions of each of neighboring first touch electrodes and portions of each of neighboring second touch electrodes; and
    - an arrangement of the spacers of each touch pattern unit block corresponds to a plurality of spacer pattern unit blocks repeatedly arranged and each spacer pattern unit includes at least one spacer and is smaller than the touch pattern unit block.
2. The organic light emitting display device of claim 1, wherein the plurality of pixels includes a plurality of pixel pattern unit blocks repeatedly arranged, each pixel pattern unit block includes at least a first pixel, a second pixel, and a third pixel that emit light corresponding to different colors.

3. The organic light emitting display device of claim 2, wherein an arrangement of the pixels of each spacer pattern unit block corresponds to K of the pixel pattern unit blocks arranged in the first direction, and L of the pixel pattern unit blocks arranged in the second direction, where K and L are natural numbers.

4. The organic light emitting display device of claim 3, wherein an arrangement of the pixels of each touch pattern unit block corresponds to M of the K of the pixel pattern unit blocks arranged in the first direction, and N of the pixel pattern unit blocks arranged in the second direction, where M is a natural number and an integer multiple of the K, and N is a natural number and an integer multiple of the L.

5. The organic light emitting display device of claim 2, wherein, in each pixel pattern unit block, the number of the third pixels is equal to a sum of the number of the first pixels and the number of the second pixels.

6. The organic light emitting display device of claim 2, wherein the at least one spacer is located at an intersection of a first virtual line connecting neighboring first pixels and second pixels, and a second virtual line connecting neighboring third pixels.

7. The organic light emitting display device of claim 1, wherein the at least one spacer comprises a first spacer adjacent to a corner of each spacer pattern unit block.

8. The organic light emitting display device of claim 7, wherein each spacer pattern unit block further comprises a second spacer separated apart from the first spacer in a third direction that forms an acute angle with respect to the first direction and the second direction.

9. The organic light emitting display device of claim 1, wherein each touch pattern unit block has a square shape.

10. The organic light emitting display device of claim 1, wherein each spacer pattern unit block has a square shape.

11. An organic light emitting display device comprising:  
a plurality of pixels, each pixel including a pixel electrode, an opposite electrode, and an organic light emitting layer located between the pixel electrode and the opposite electrode;

a plurality of spacers disposed between neighboring pixels and spaced apart from each other; and

a touch electrode unit disposed over the plurality of pixels and the plurality of spacers, the touch electrode unit including first touch electrodes arranged in a first direction and second touch electrodes arranged in a second direction substantially perpendicular to the first direction, wherein:

the touch electrode unit includes a plurality of touch pattern unit blocks repeatedly arranged and each touch pattern unit block includes portions of each of neighboring first touch electrodes and portions of each of neighboring second touch electrodes; and

the plurality of spacers includes a plurality of spacer pattern unit blocks repeatedly arranged and each spacer pattern unit block includes at least one spacer and is smaller than the touch pattern unit block.

12. The organic light emitting display device of claim 11, wherein each of the first touch electrodes and each of the second touch electrodes include wires of a net structure at least partially surrounding each of the plurality of pixels.

13. The organic light emitting display device of claim 12, wherein the plurality of spacers overlap the wires of the first touch electrodes or the wires of the second touch electrodes.

14. The organic light emitting display device of claim 11, wherein an arrangement of the spacers corresponding to each touch pattern unit block corresponds to the arrangement of the spacers according to an AxB array of the spacer pattern unit blocks, where A and B are natural numbers.

15. The organic light emitting display device of claim 11, wherein the plurality of pixels includes a plurality of pixel pattern unit blocks repeatedly arranged, each pixel pattern unit block includes at least three pixels that emit light corresponding to different colors, and the arrangement of pixels of each spacer pattern unit block corresponds to K of the pixel pattern unit blocks arranged in the first direction or in the second direction, where K is a natural number.

16. The organic light emitting display device of claim 11, wherein the plurality of pixels includes a plurality of pixel pattern unit blocks repeatedly arranged, each pixel pattern unit block includes at least three pixels that emit light corresponding to different colors, and the arrangement of the pixels of each touch pattern unit block corresponds to M of the pixel pattern unit blocks arranged in the first direction or in the second direction, where M is a natural number.

17. The organic light emitting display device of claim 11, wherein the plurality of pixels includes a first pixel, a second pixel, and a third pixel that emit light corresponding to different colors, and the at least one spacer is located at an intersection of a first virtual line connecting neighboring first pixels and second pixels, and a second virtual line connecting neighboring third pixels.

18. The organic light emitting display device of claim 17, wherein the at least one spacer comprises a first spacer adjacent to one corner of each spacer pattern unit block.

19. The organic light emitting display device of claim 18, wherein each spacer pattern unit block further comprises a second spacer spaced apart from the first spacer in a third direction crossing the first direction and the second direction.

20. The organic light emitting display device of claim 11, wherein each touch pattern unit block and each spacer pattern unit block have a square shape.

21. An organic light emitting display device comprising:  
a substrate including a plurality of pixel areas and a pixel separating area between the pixel areas;

a plurality of pixels corresponding to each of the plurality of pixel areas, each of the pixels including a pixel electrode, an opposite electrode, and an organic light emitting layer located between the pixel electrode and the opposite electrode;

a plurality of spacers disposed in the pixel separating area and spaced apart from each other; and

a touch electrode layer disposed over the plurality of pixels and the plurality of spacers, the touch electrode layer comprising:

first touch electrodes and second touch electrodes arranged in a first direction;

third touch electrodes and fourth touch electrodes arranged in a second other direction;

a first connection line connecting the first and second touch electrodes together; and

a second connection line connecting the third and fourth touch electrodes together,

wherein the first direction is perpendicular to the second direction.

22. The organic light emitting display device of claim 21, where a first spacer among the spacers is adjacently disposed

between a first pixel, a second pixel, a third pixel, and a fourth pixel among the pixels, the first pixel emitting a first color, the second pixel emitting a second color, and the third and fourth pixels emitting a third color.

**23.** The organic light emitting display device of claim **22**, wherein the first and second pixels are arranged on the first direction and the third and fourth pixels are arranged in the second direction.

\* \* \* \* \*

专利名称(译)	有机发光显示装置		
公开(公告)号	<a href="#">US20180286925A1</a>	公开(公告)日	2018-10-04
申请号	US15/833265	申请日	2017-12-06
[标]申请(专利权)人(译)	三星显示有限公司		
申请(专利权)人(译)	三星DISPLAY CO. , LTD.		
当前申请(专利权)人(译)	三星DISPLAY CO. , LTD.		
[标]发明人	KIM KWANGMIN KWAK WONKYU KIM KIWOOK KIM DONGSOO MOON JOONGSOO PARK HYUNAE LEE JIEUN JIN CHANGKYU		
发明人	KIM, KWANGMIN KWAK, WONKYU KIM, KIWOOK KIM, DONGSOO MOON, JOONGSOO PARK, HYUNAE LEE, JIEUN JIN, CHANGKYU		
IPC分类号	H01L27/32 H01L51/50 H01L51/52		
CPC分类号	H01L27/323 H01L51/5044 H01L51/5203 G06F3/0412 H01L27/322 H01L27/3244 H01L27/3246 H01L27/326 G06F3/044 G06F2203/04111 G06F2203/04112 H01L51/525		
优先权	1020170041060 2017-03-30 KR		
其他公开文献	US10692942		
外部链接	<a href="#">Espacenet</a> <a href="#">USPTO</a>		

摘要(译)

一种有机发光显示装置，包括：基板，包括像素区域和像素分离区域；多个像素；像素分离区域中的多个间隔物并且彼此间隔开；触摸电极单元设置在多个像素和间隔物上方。触摸电极单元包括沿第一方向布置的第一触摸电极和沿第二方向布置的第二触摸电极。触摸电极单元包括重复布置的多个触摸图案单元块。每个触摸图案单元块包括每个相邻的第一触摸电极的部分和每个相邻的第二触摸电极的部分。每个触摸图案单元块的间隔物对应于重复排列的多个间隔物图案单元块。每个间隔物图案单元块包括至少一个间隔物并且小于触摸图案单元块。

